

# NEPTUNE HOT

## Range of Integral Hot Food Counters

**Capital Cooling** is a market leader in the supply, installation and maintenance of food retailing and food service equipment.

Our new range of display equipment has been designed and engineered to offer the highest standards of performance, aesthetics and merchandising, previously unseen in the food retailing sector.



PIES



PASTIES



SAUSAGE ROLLS



SAVOURIES



PASTA



### MERCHANDISING INNOVATION

- 3 tier shelves and base for merchandising flexibility
- Available in 2 case lengths to suit retailing requirements
- Central and shelf lighting for high visual impact
- Glass service doors to the rear of the counter
- Complementary chilled, ambient and cash counters available for cross merchandising

### AESTHETIC APPEAL

- Stainless steel finish as standard
- Optional wood effect finish with gold coloured door frame
- Attractive curved glass profile
- Glass end walls for maximum visibility of merchandise
- Optional toughened glass
- Narrow footprint



REFRIGERATION FOR THE NATION

# NEPTUNE HOT

## Range of Integral Hot Food Counters

### ENGINEERING FEATURES

- Operating temperature of +65°C suitable for a range of hot food
- Convection heating system for stable and uniform temperatures
- Electronic controller for accurate set-up and temperature control

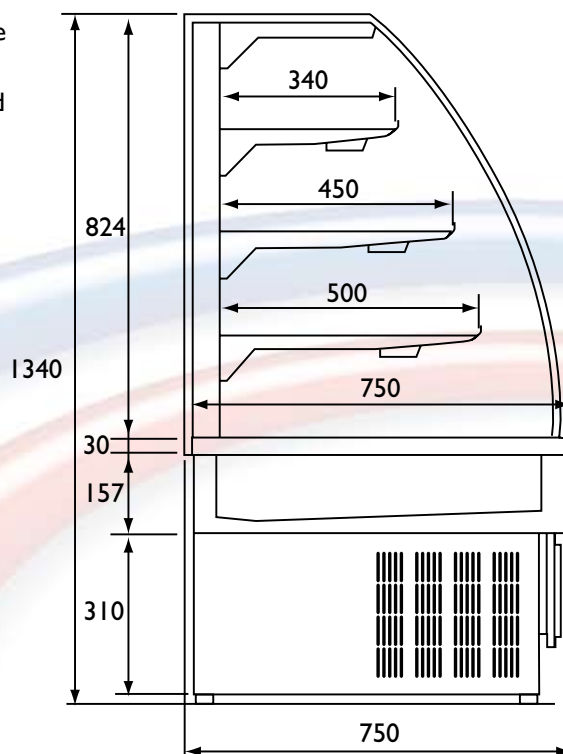

Dimensions in mm

### TECHNICAL SPECIFICATIONS

Model no	Neptune Hot 10	Neptune Hot 15
Case length mm	996	1497
Display area m <sup>2</sup>	1.94	2.96
Weight Kg	190	250
Electricity Supply Amp	13	13
Voltage	220V – 50Hz	
Operating temperature [i]	+65°C	

[i] Operating temperatures quoted are based on a maximum ambient of 25°C / 60% R.H

To complement the Neptune hot food counter, we offer a comprehensive range of integral and remote refrigeration equipment for the food retailing sector. For further details, please contact our Sales Office.

The modular nature of the Neptune Hot range, together with our flexible manufacturing techniques, permits product customisation to meet house styles and colours.

We reserve the right to change or revise specifications and design in connection with any feature of our products.

All installations should be undertaken by a competent electrician and comply with IEE regulation BS7671.

CAPITAL COOLING LTD  
12 Dunnet Way · East Mains Industrial Estate  
Broxburn · West Lothian · EH52 5NN  
Tel: + 44 (0) 1506 859000 · Fax: + 44 (0) 1506 859123  
Email: sales@capitalcooling.com  
www.capitalcooling.com



REFRIGERATION FOR THE NATION